



Catholic Charities

ARCHDIOCESE OF WASHINGTON

Inspiring Hope, Building Futures.

Make Cloth Face Covers for Catholic Charities

Catholic Charities needs your help. Do you have these 5 things: **a sewing machine, cloth and elastics ready in your home (don't go out shopping!), a printer, an envelope or box, a couple dollars to pay for shipping.**

Help us by making sewn cloth face coverings for our onsite staff at shelters and food distribution programs and for our shelter residents. Catholic Charities remains committed to the most marginalized in our community during this public health crisis. We continue to prioritize the safety of everyone while serving people in our care. Or, donate to our [COVID-19 Fund](#) to help cover the cost for essential supplies.

With your help and generosity, we can continue to follow CDC guidelines and keep our community safe. We cannot purchase surgical masks. They simply are not available, so we are turning to you.

Our Goals: **Provide each staff member with 3-sewn cloth face covers 2x a month**
Give each shelter resident and food program client a sewn cloth face cover

The production of Homemade face coverings help alleviate the mask shortage and allow for some level of protection for members of our community who do not have access to medical grade masks, and for those whom physical distancing is not an option. This includes our front-line staff and our residents.

Please read the **Instructions** below before starting and **please do not send face coverings if you have had any symptoms or known exposure to COVID-19 within the last 14 days.**

Instructions:

Step 1: [Sign up](#) to make and send us a minimum of 3 sewn cloth face covers

Step 2: Make at least 3 Sewn Cloth Face Coverings

We are only using and accepting Sewn Cloth Face Coverings instructions provided by the CDC. [Please see printer friendly PDF](#) or images below.

Tips:

- **Use** new, unused, breathable material such as 100% cotton by CDC guidelines.
- **Use** lighter colors when possible, as it is easier to see soiling.
- **Use** different colors on the front and the back (inside facing) part of the mask so that the sides can easily be recognized.

Step 3: Mail and Ship Sewn Cloth Face Coverings

- Place your finished face coverings directly in a box or envelope, seal with tape, and once taped shut please do NOT open the box or envelope again.
- Use the mail service of your choice – USPS, UPS, Fed Ex. NO DROP OFFS!
 - Where are you sending to:
 - Company name: Catholic Charities-Hickey Center
 - Address: 924 G ST NW, WASHINGTON, DC 20001-4532 United States
 - The mail services may allow you to schedule a pickup from your house.
- Questions? Email Volunteer@cc-dc.org

Step 4: Share what you've done!

- Join the Catholic Charities community on social media. Post photos of your creations and tag us at @CCADW!
- Forward this message to 10 friends, your book club, your sewing club . . . Thank you!

Use Cloth Face Coverings to Help Slow Spread. (2020, April 4). Retrieved from <https://www.cdc.gov/coronavirus/2019-ncov/prevent-getting-sick/diy-cloth-face-coverings.html>

Sewn Cloth Face Covering

Materials

- Two 10"x6" rectangles of cotton fabric
- Two 6" pieces of elastic (or rubber bands, string, cloth strips, or hairties)
- Needle and thread (or bobby pin)
- Scissors
- Sewing machine

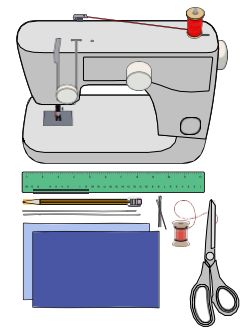

Tutorial

1. Cut out two 10-by-6-inch rectangles of cotton fabric. Use tightly woven cotton, such as quilting fabric or cotton sheets. T-shirt fabric will work in a pinch. Stack the two rectangles; you will sew

the cloth face covering as if it was a single piece of fabric.

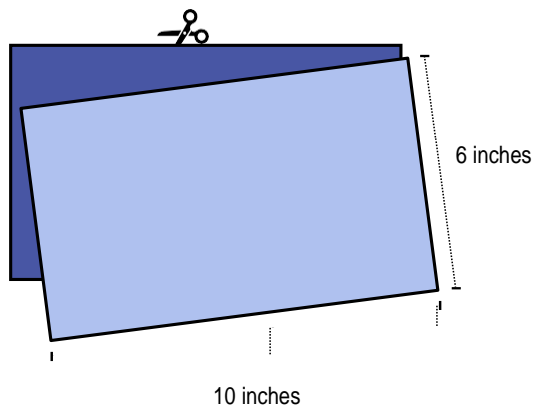

2. Fold over the long sides $\frac{1}{4}$ inch and hem. Then fold the double layer of fabric over $\frac{1}{2}$ inch along the short sides a

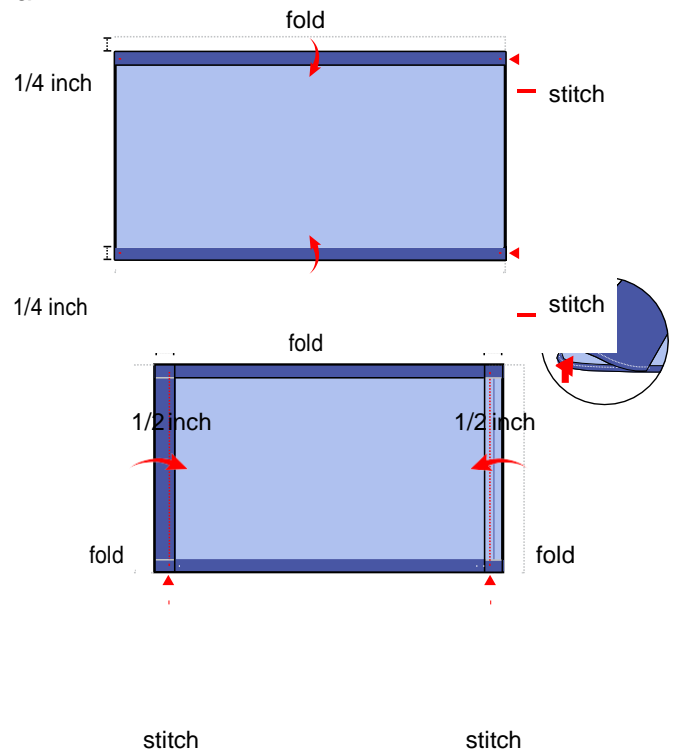

3. Run a 6-inch length of $\frac{1}{8}$ -inch wide elastic through the wider hem on each side of the cloth face covering. These will be the ear loops. Use a large needle or a bobby pin to thread it through. Tie the ends tight.

Don't have elastic? Use hair ties or elastic head bands. If you only have string, you can make the ties longer and tie the cloth face covering behind your head.

4. Gently pull on the elastic so that the knots are tucked inside the hem. Gather the sides of the cloth face covering on the elastic and adjust so the cloth face covering fits your face. Then securely stitch the elastic in place to keep it from slipping.

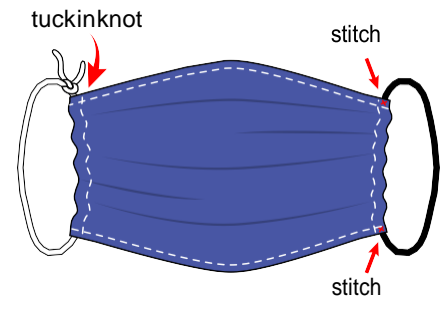
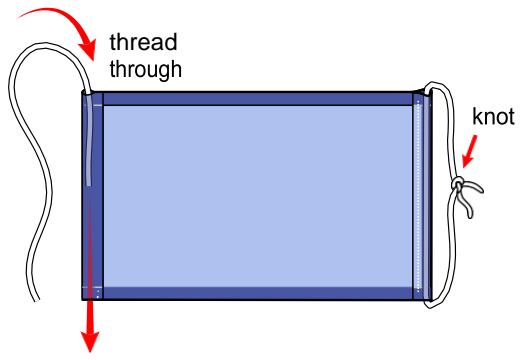

Sewn Cloth Face Covering

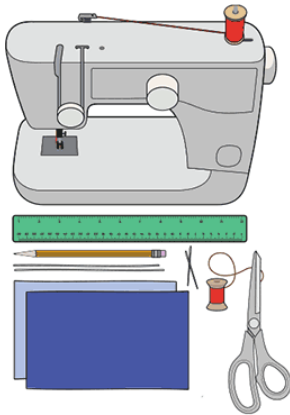

Materials

- Two 10"x6" rectangles of cotton fabric
- Two 6" pieces of elastic (or rubber bands, string, cloth strips, or hair ties)
- Needle and thread (or bobby pin)
- Scissors
- Sewing machine

Tutorial

1. Cut out two 10-by-6-inch rectangles of cotton fabric. Use tightly woven cotton, such as quilting fabric or cotton sheets. T-shirt fabric will work in a pinch. Stack the two rectangles; you will sew the mask as if it was a single piece of fabric.

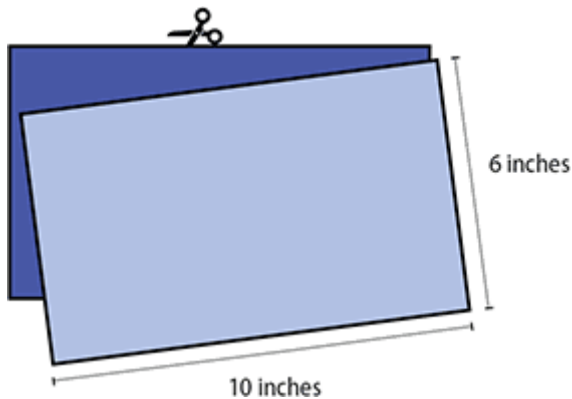

2. Fold over the long sides $\frac{1}{4}$ inch and hem. Then fold the double layer of fabric over $\frac{1}{2}$ inch along the short sides and stitch down.

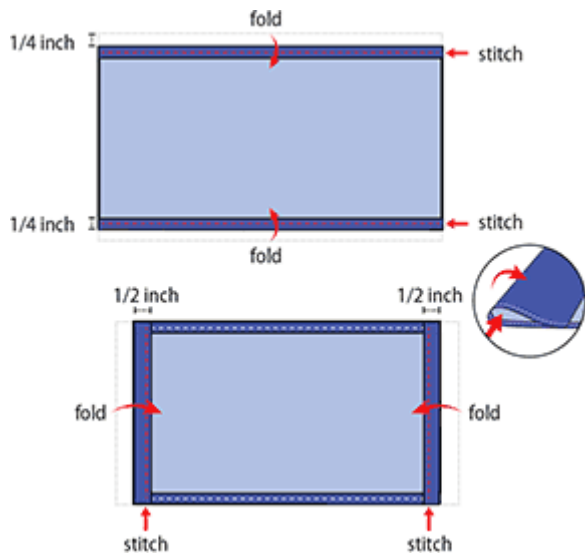

3. Run a 6-inch length of 1/8-inch wide elastic through the wider hem on each side of the mask. These will be the ear loops. Use a large needle or a bobby pin to thread it through. Tie the ends tight. Don't have elastic? Use hair ties or elastic head bands. If you only have string, you can make the ties longer and tie the mask behind your head.

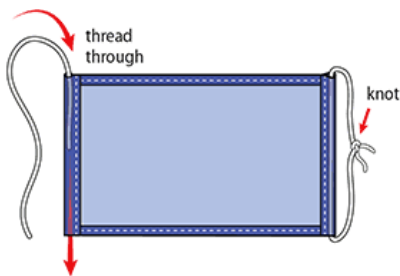

4. Gently pull on the elastic so that the knots are tucked inside the hem. Gather the sides of the mask on the elastic and adjust so the mask fits your face. Then securely stitch the elastic in place to keep it from slipping.

